

MATH 202-01

FINAL EXAM

Fall, 2001

Name: _____

Student ID: _____

Page	Points Possible	Score
2	30	
3	27	
4	26	
5	27	
6	10	
7	29	
8	12	
9	24	
10	15	
Total	200	

- (5) 1. Which of these is safe to say about every square pyramid?
X. Every lateral edge has the same length.
Y. All of the angles on each face are equal.
Z. Every base edge has the same length.
- A. X only B. Y only C. Z only D. X and Z only E. None of A-D
- (5) 2. If a polygon is equiangular, then it must be:
A. equilateral B. regular C. a triangle D. both A and B E. none of A-D
- (5) 3. If IJKLMN is a regular polygon, then...
A. all the diagonals are equal in length.
B. IJKLMN has 7 sides.
C. angle JKL has twice as many degrees as angle LMN.
D. IJKLMN has exactly 7 symmetries.
E. none of A-D
- (5) 4. If the volume of a right circular cylinder with radius 5 cm is about 550 cubic cm, about what is the height of the cylinder?
A. 110 cm B. 35 cm C. 22 cm D. 7 cm E. 3 cm
- (5) 5. A triangle is similar to a larger triangle that has lengths 3 times as long as the corresponding lengths in the smaller triangle. How large is the angle in the smaller triangle that corresponds to a 30° angle in the larger triangle?
A. 10° B. 30° C. 90° D. 270° E. None of A-D
- (5) 6. What is the area of a triangle similar to the one below, which has undergone a size transformation of factor 3?

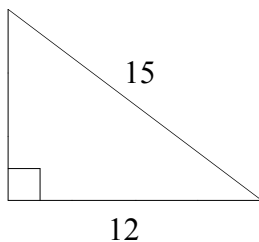

- A. 270 B. 54 C. 486 D. 162 E. None of the above

- (5) 7. What is the surface area of a cube with volume 64?
A. 48 B. 384 C. 512 D. 96 E. None of the above
- (5) 8. Which of the following are nets of a pyramid with a square base? **CIRCLE ALL THAT APPLY.**
- (9) 9. What is the sum of the number of edges and the number of vertices of an octagonal pyramid?

Ans: _____

- (8) 10. How many faces cannot be seen in this drawing of a pentagonal pyramid?

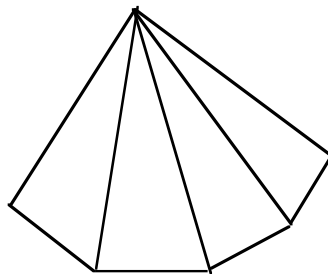

Ans: _____

(8) 11. T/F: A polyhedron with 8 edges could be a prism. If true, sketch an example; if not, explain why not.

(8) 12. An isosceles triangle has two angles, one with 40° and the other with 100° . How large is the third angle?

Ans: _____

(10) 13. Find the length of diagonal AC in the following right rectangular prism.

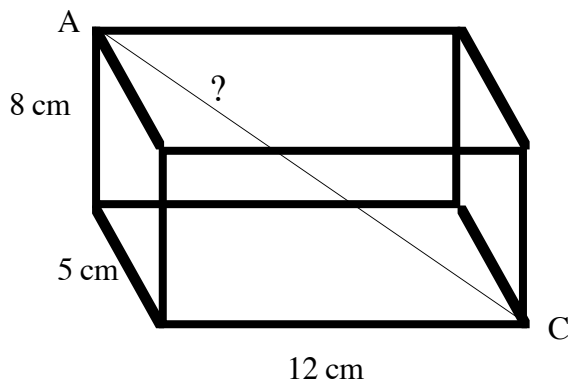

Ans: _____

- (9) 14. What is the area of a rectangle with perimeter 20 meters and base 6 meters?

Ans: _____

- (8) 15. Susan is 166 cm tall and in the afternoon she casts a shadow about 55 cm long. Her sister, who is standing next to her, casts a shadow about 35 cm long. About how tall is Susan's sister?

Ans: _____

- (10) 16. What is the area of the hexagonal region to the right, in square centimeters? Assume that lines that look parallel are parallel, and that angles that look like right angles are right angles.

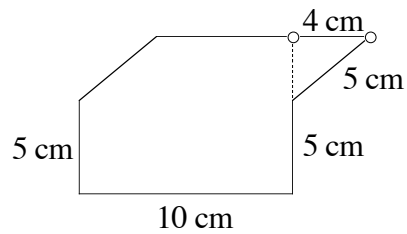

Ans: _____

(10) 17. For each of the following, sketch an example if it is possible. If it is impossible, say so and *explain why*. (2 pts. ea.)

a. A triangle that is isosceles and acute.

b. A rhombus that is not a parallelogram.

c. A trapezoid that is not a parallelogram.

d. A square that is not a kite.

e. A quadrilateral with exactly 2 lines of symmetry.

- (6) 18. Draw in all lines of symmetry and list all angles of rotation symmetry in each of the shapes below. (2 pts. ea.)

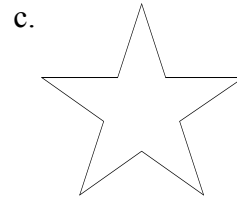
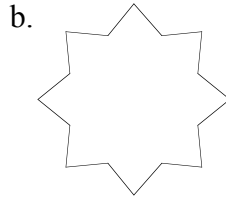
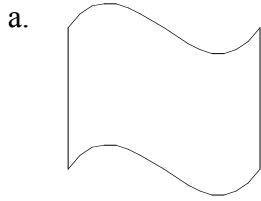

- (8) 19. Fill in the blanks with the correct value (2 pts. ea.):

a. 25 is _____ % more than 10.

b. 15 is _____ % of 6.

c. The two-hour final exam is _____ times as long as the $\frac{4}{3}$ -hour long regular class session.

d. The $\frac{4}{3}$ -hour regular class is _____ times long than a typical 50-minute class session.

- (15) 20. Suppose I reported the length of a bookshelf to be 2.12 meters. What range would you expect the actual length of the bookshelf to lie in? Explain your answer.

- (15) 24. In the following diagram, \overline{AB} is parallel to \overline{CE} and \overline{AD} is parallel to \overline{BE} . Explain why the area of $\triangle ABC$ must equal the area of $\triangle BDE$.

